

REVISION HISTORY			
REV	DESCRIPTION	DATE	APPROVED

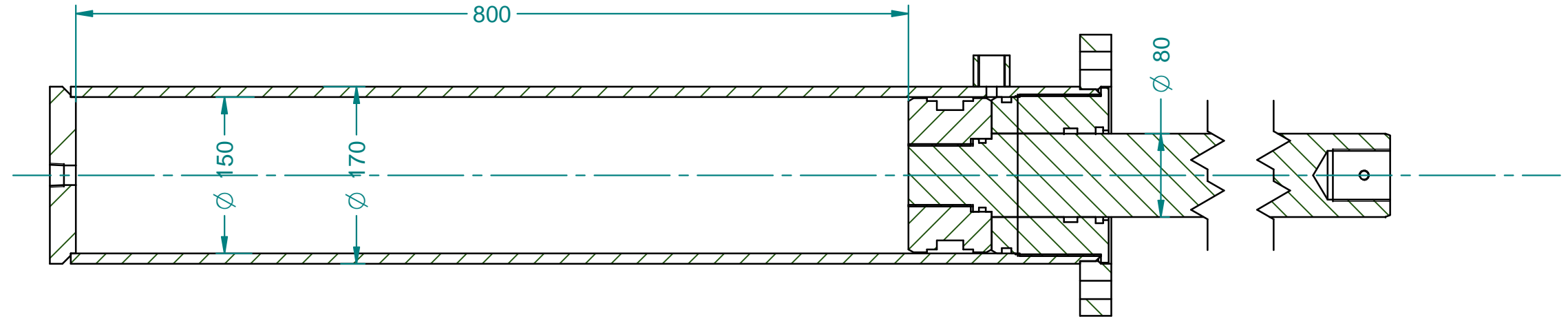
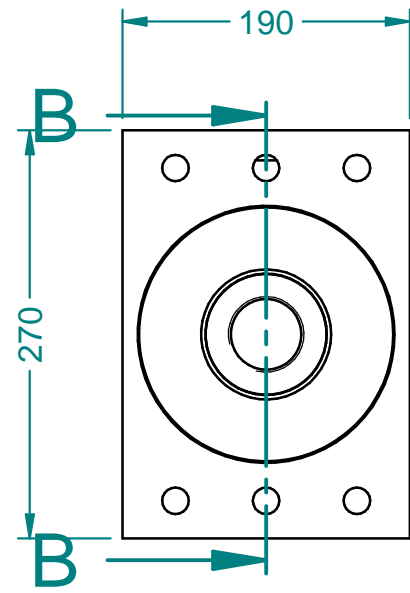

SECTION B-B

	NAME	DATE	PROJECT	
DRAWN			ASM. Drg.	
APPROVED			TITLE	
MATERIAL			DESCRIPTION	
QUANTITY				
<small>This drawing is the property of Al Tashreef Hydraulics LLC, Sharjah, UAE & May not be reproduced or employed in any form without written permission.</small> <small>All dimensions are in mm, unless otherwise specified.</small>			A3 DWG NO	REV
		SCALE:	Wt Kg:	SHEET :

REVISION HISTORY			
REV	DESCRIPTION	DATE	APPROVED

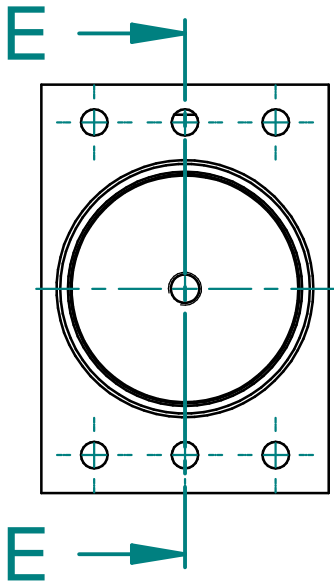

SECTION E-E

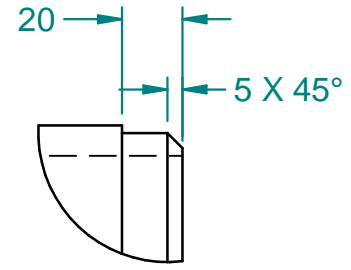
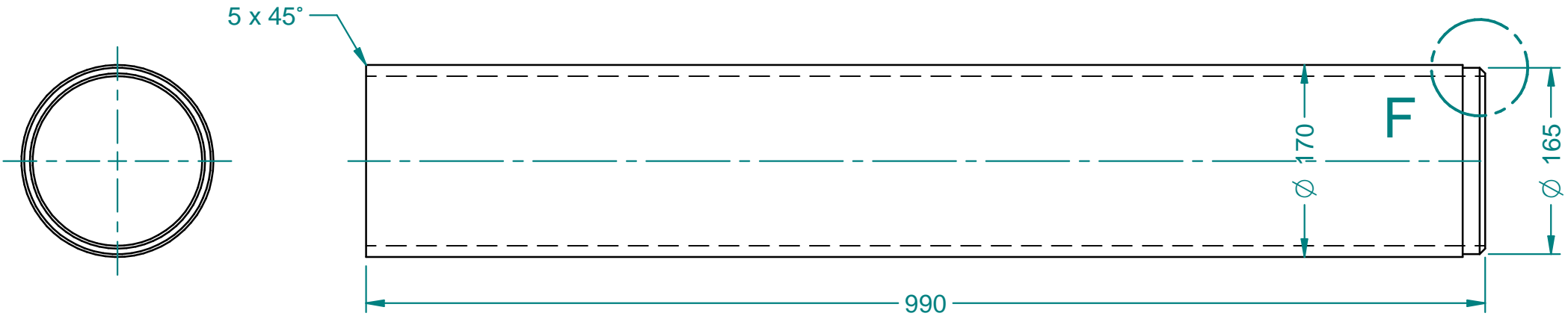

DETAIL F

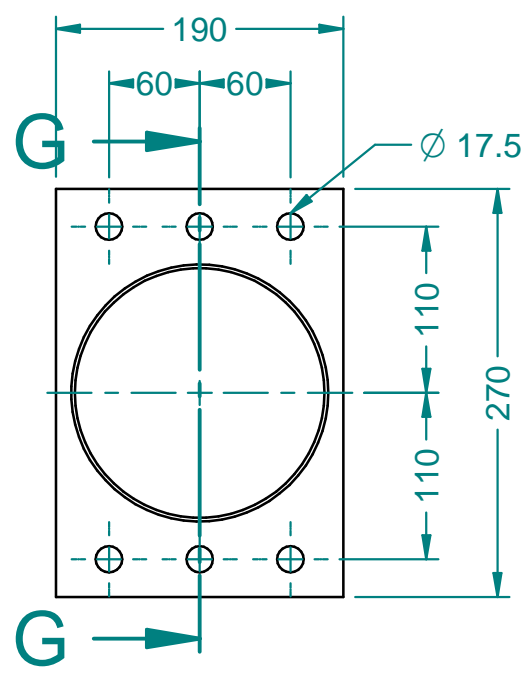

SECTION G-G

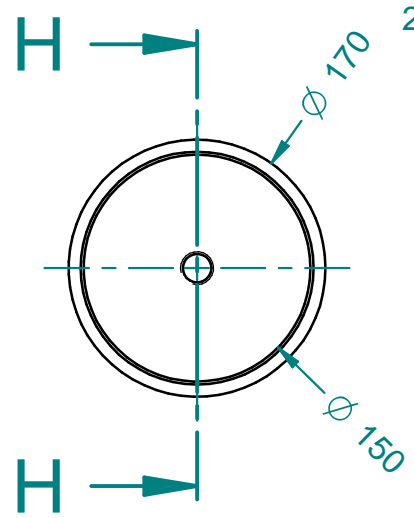
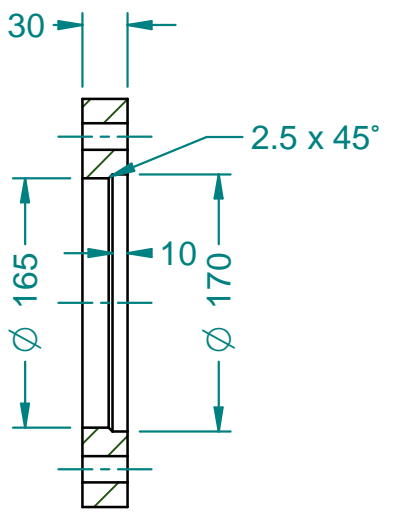

SECTION H-H

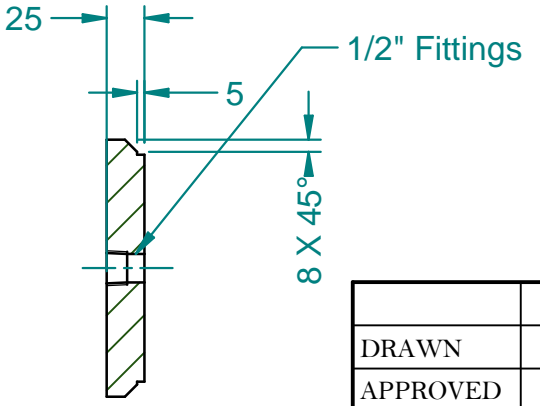

	NAME	DATE	PROJECT	
DRAWN			ASM. Drg.	
APPROVED			TITLE	
MATERIAL				
QUANTITY			DESCRIPTION	
<small>This drawing is the property of Al-Tasheed Hydraulics LLC, Sharjah, UAE & May not be reproduced or employed in any form without written permission. All dimensions are in mm, unless otherwise specified.</small>				
	A3	DWG NO		REV
SCALE:	Wt	Kg:	SHEET :	

REVISION HISTORY			
REV	DESCRIPTION	DATE	APPROVED

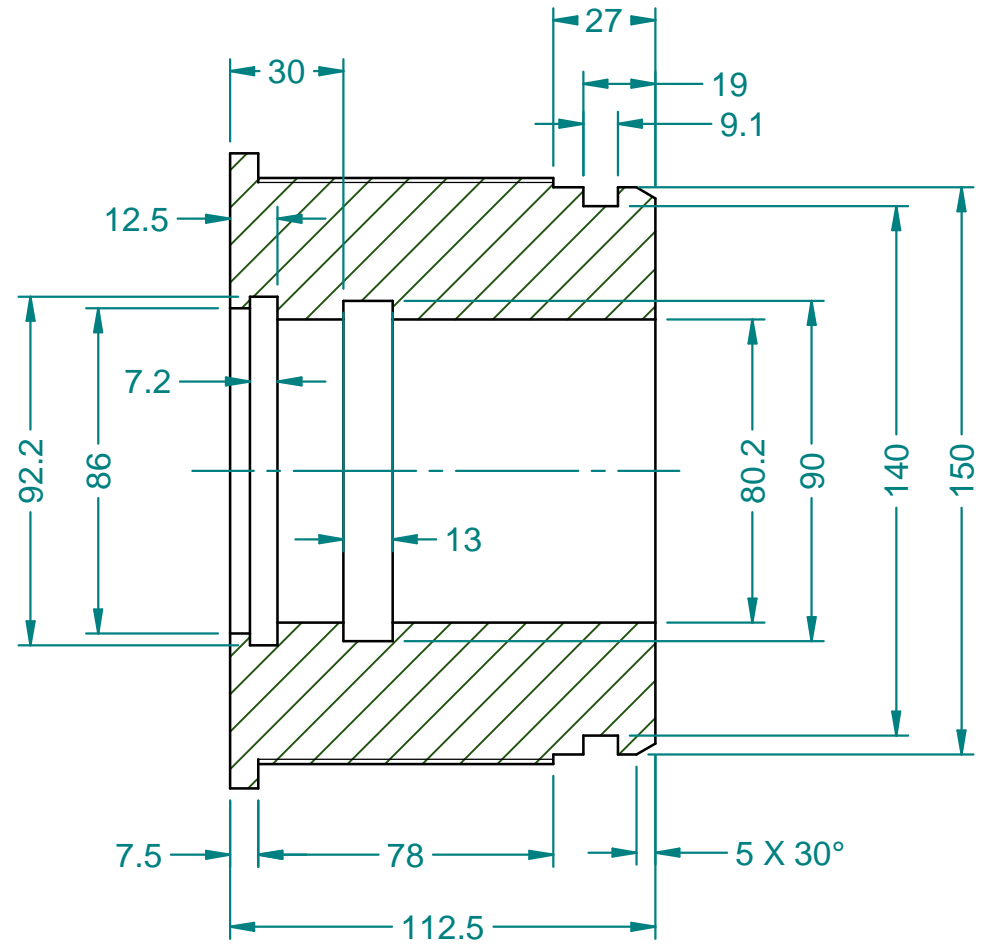
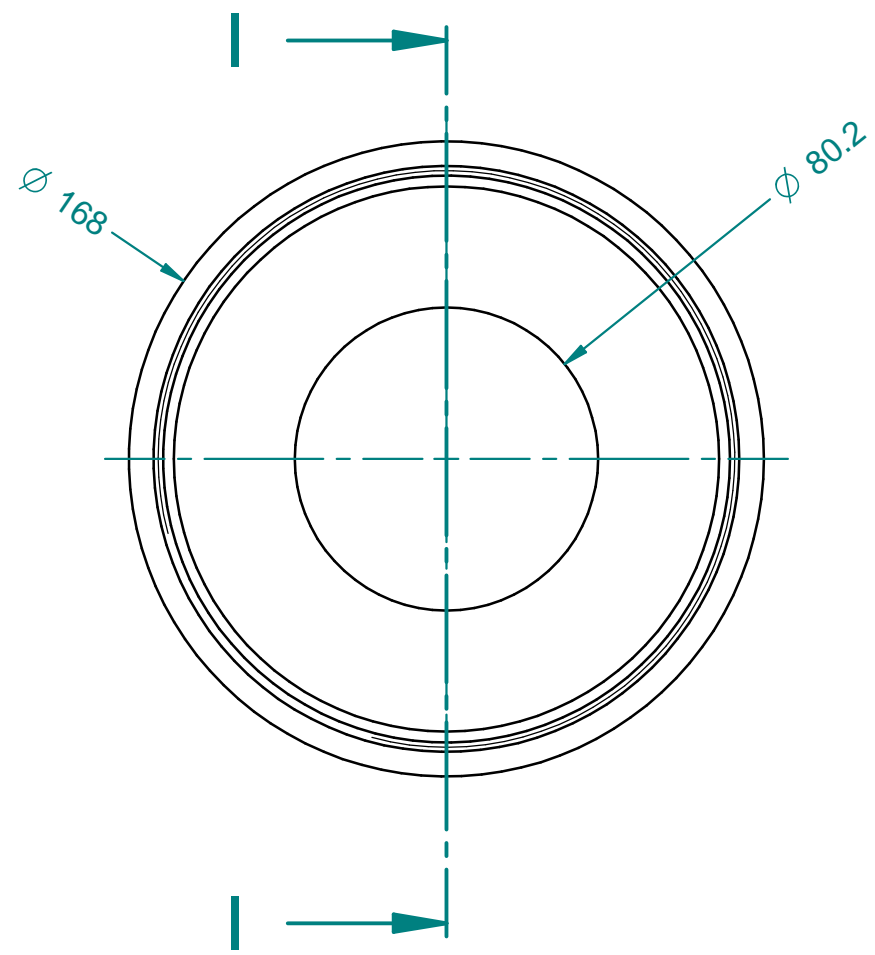

SECTION I-I

	NAME	DATE	PROJECT	
DRAWN			ASM. Drg.	
APPROVED			TITLE	
MATERIAL			DESCRIPTION	
QUANTITY				
<small>This drawing is the property of Al-Tasheet Hydraulics LLC, Sharjah, UAE & May not be reproduced or employed in any form without written permission.</small> <small>All dimensions are in mm, unless otherwise specified.</small>			A3 DWG NO	REV
	SCALE:	Wt Kg:	SHEET :	

REVISION HISTORY			
REV	DESCRIPTION	DATE	APPROVED

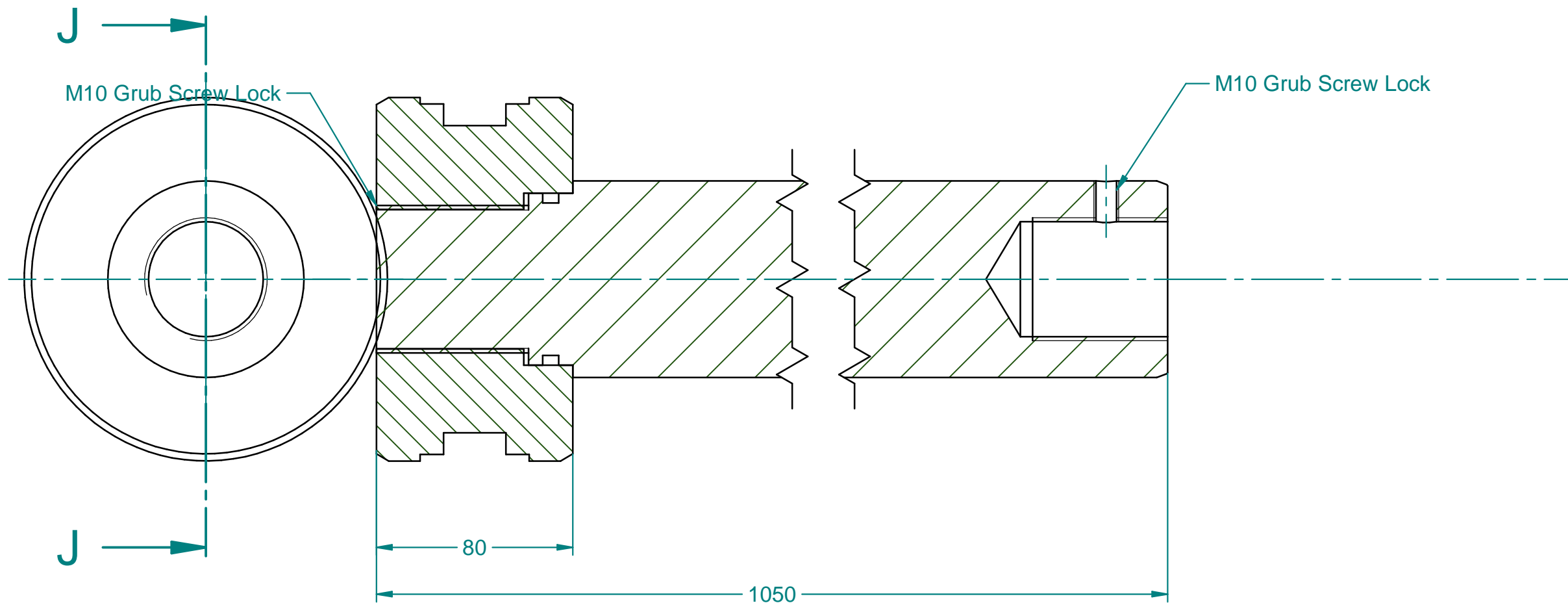

SECTION J-J

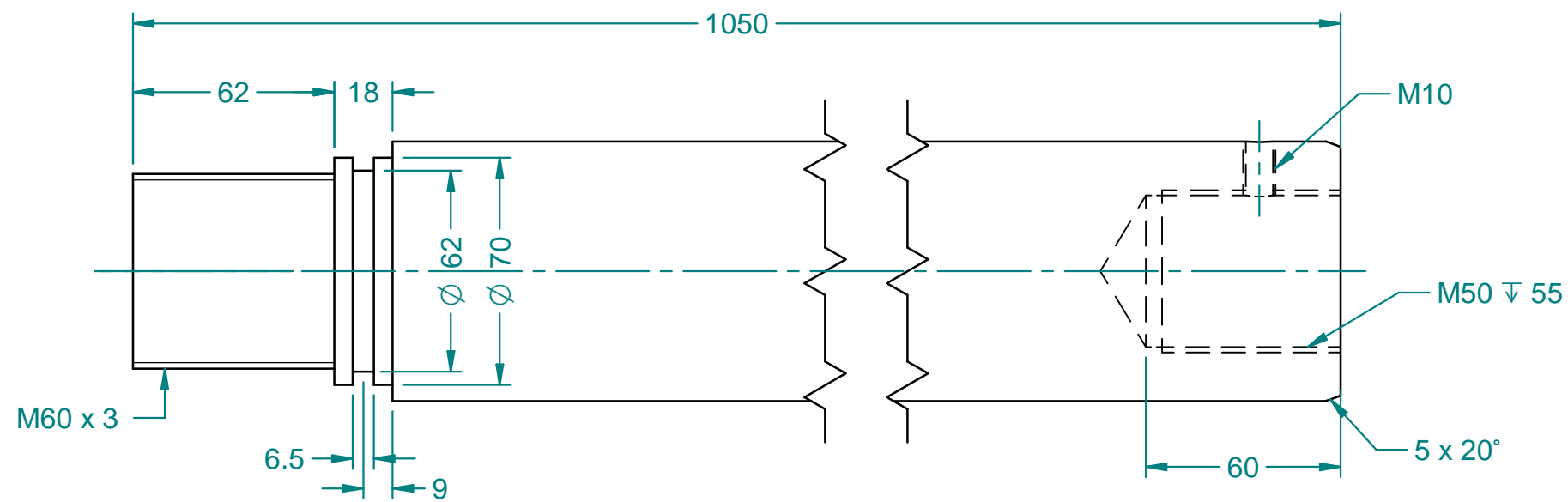

	NAME	DATE	PROJECT	
DRAWN			ASM. Drg.	
APPROVED			TITLE	
MATERIAL			DESCRIPTION	
QUANTITY				
<small>This drawing is the property of Al Tashreef Hydraulics LLC, Sharjah, UAE & May not be reproduced or employed in any form without written permission.</small> <small>All dimensions are in mm, unless otherwise specified.</small>				
			A3 DWG NO	REV
			SCALE:	Wt Kg: SHEET :

REVISION HISTORY

REV	DESCRIPTION	DATE	APPROVED

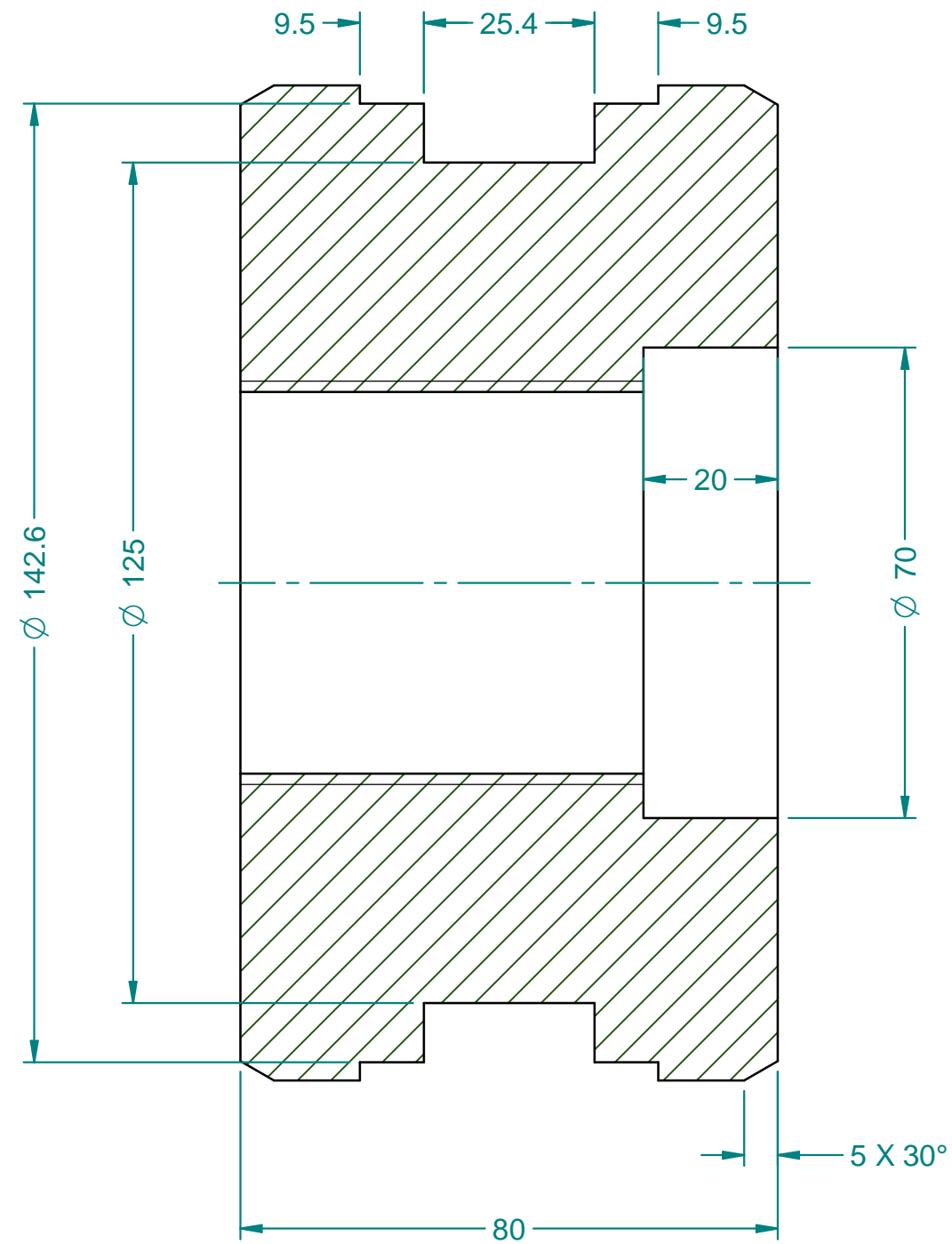
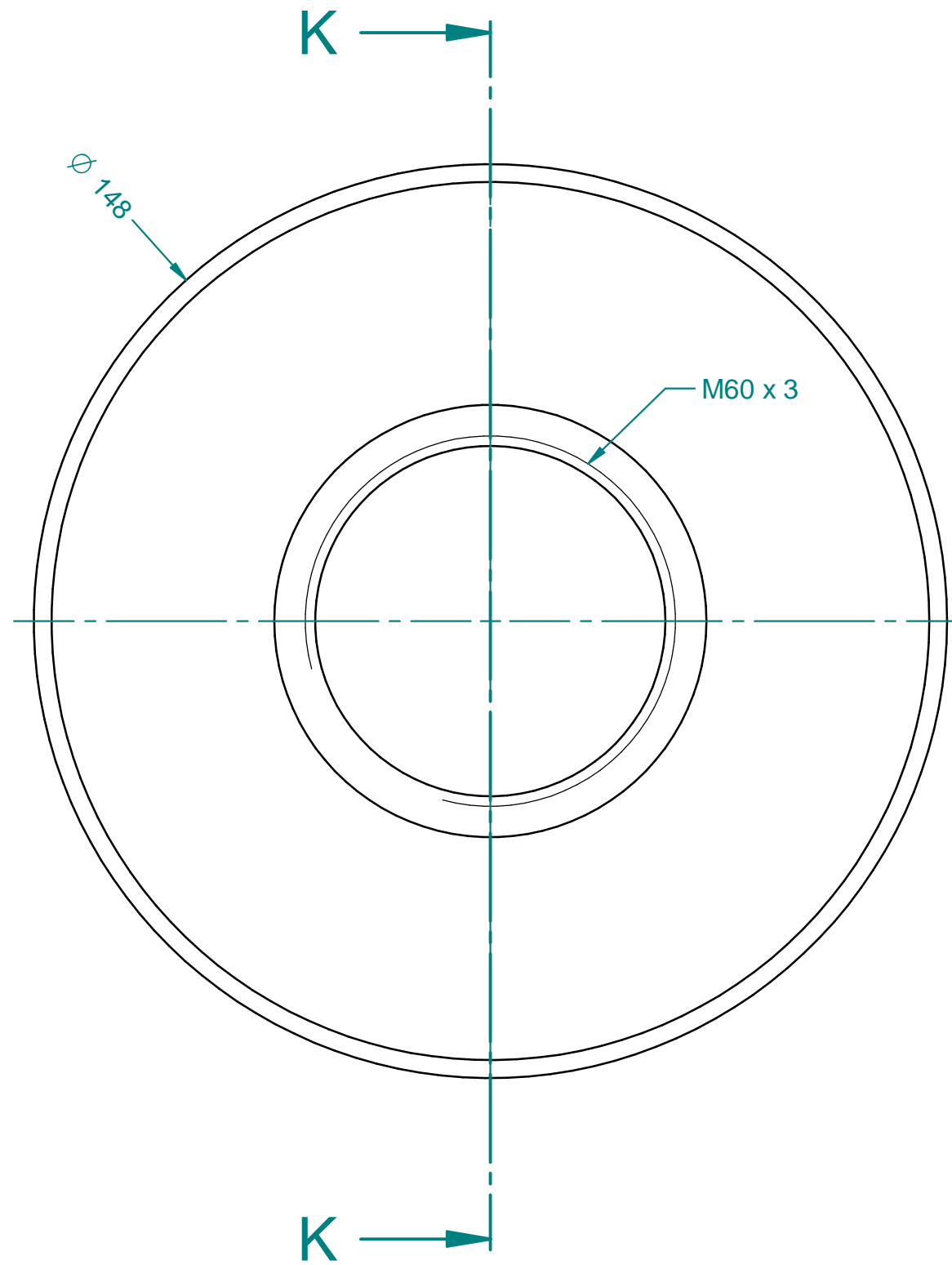

SECTION K-K

	NAME	DATE	PROJECT	
DRAWN			ASM. Drg.	
APPROVED			TITLE	
MATERIAL			DESCRIPTION	
QUANTITY				
<small>This drawing is the property of Al Tashreef Hydraulics LLC, Sharjah, UAE & May not be reproduced or employed in any form without written permission.</small> <small>All dimensions are in mm, unless otherwise specified.</small>			DWG NO A3	REV
	SCALE:	Wt Kg:	SHEET :	